



2x2 Ultra-Lok housing with a filter in the upper-right corner

Typically installed on the exhaust of the fan

PROVIDES A STURDY HOUSING FOR HEPA AFTERFILTERS

- Modular construction specifically designed to integrate with any Donaldson® Torit® dust collection system
- Provides backup filtration in the event of dust collector leakage
- Pressure gauge identifies service requirements for better performance monitoring capabilities
- Access from both sides provides easy filter changeout with no tools
- HEPA final filter provides 99.97% efficiency on 0.3 µm particles
- Configured to hold 1, 2, 3, 4, 6, 8, 9, or 12 HEPA filters and Air-O-J™ prefilters
- Compact, self-contained unit designed for flexible floor placement to conserve space
- Durable 14 gauge carbon construction resists rust and corrosion
- Recirculates clean air, eliminating the need for costly make-up air

DIMENSIONS & SPECIFICATIONS

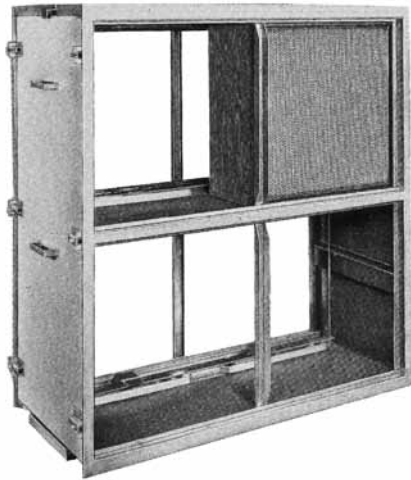

2 x 2 Ultra-Lok Housing

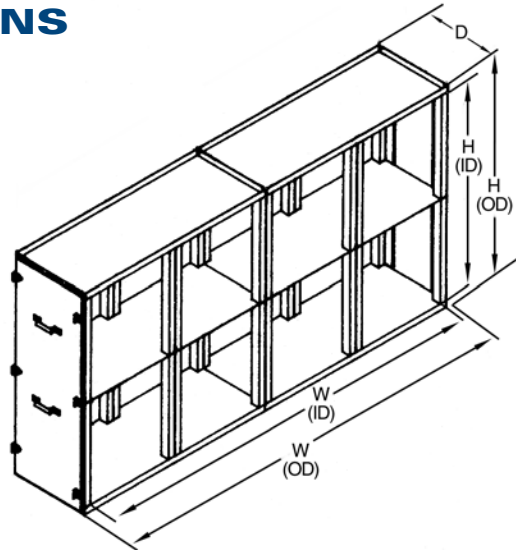

2 x 4 Ultra-Lok Housing

Modules	Capacity		Dimensions									
			Height				Width				Depth	
	in	cfm	m ³ /h	ID		OD		ID		OD		in
1 x 1	2,000	3,397	24.2	614.4	28.2	716.0	23.9	606.0	26.6	676.1	23.0	584.2
1 x 2	4,000	6,795	24.2	614.4	28.2	716.0	48.1	1220.5	50.8	1290.6	23.0	584.2
1 x 3	6,000	10,192	24.2	614.4	28.2	716.0	72.2	1832.6	74.9	1902.7	23.0	584.2
1 x 4	8,000	13,589	24.2	614.4	28.2	716.0	96.2	2444.5	99.0	2514.6	23.0	584.2
2 x 1	4,000	6,795	49.5	1257.3	53.5	1358.9	23.9	606.0	26.6	676.1	23.0	584.2
2 x 2	8,000	13,589	49.5	1257.3	53.5	1358.9	48.1	1220.5	50.8	1290.6	23.0	584.2
2 x 3	12,000	20,384	49.5	1257.3	53.5	1358.9	72.2	1832.6	74.9	1902.7	23.0	584.2
2 x 4	16,000	27,178	49.5	1257.3	53.5	1358.9	96.2	2444.5	99.0	2514.6	23.0	584.2
3 x 1	6,000	10,192	74.8	1900.2	78.8	2001.8	23.9	606.0	26.6	676.1	23.0	584.2
3 x 2	12,000	20,384	74.8	1900.2	78.8	2001.8	48.1	1220.5	50.8	1290.6	23.0	584.2
3 x 3	18,000	30,576	74.8	1900.2	78.8	2001.8	72.2	1832.6	74.9	1902.7	23.0	584.2
3 x 4	24,000	40,768	74.8	1900.2	78.8	2001.8	96.2	2444.5	99.0	2514.6	23.0	584.2

The unit is designed to handle up to 3" (76.2 mm) of positive static pressure. All units include housing, HEPA filters and Air-O-J prefilters. Bottom and top interface flanges for customer ductwork are 2" (50.8 mm) wide and side interface flanges are 1-3/8" (34.9 mm) wide. All interface flanges are located outside of the airstream. Filters are 24" x 24" (609.6 x 609.6 mm) nominal.

EQUIPMENT OPTIONS

- Gauge Kit, 4228601, includes Magnehelic®* gauge, tubing, and connection fittings.

* Magnehelic is a registered trademark of Dwyer Instruments, Inc.

The Auto-Lok housing is NOT intended for outdoor installation. If the housing is installed outdoors, provisions should be made to protect the housing from the elements.

Significantly improve the performance of your collector with genuine Donaldson Torit replacement filters and parts. **Call Donaldson Torit today 800-365-1331.**



Tel 800-365-1331 (USA)
Tel 800-343-3639 (within Mexico)

donaldsontorit@donaldson.com
donaldsontorit.com

Donaldson Company, Inc.
Torit
P.O. Box 1299
Minneapolis, MN
55440-1299 U.S.A.

EXACTLY WHAT YOU NEED.™

Ultra-Lok Afterfilter Housing System (11/12)
© 1991 Donaldson Co., Inc. All Rights Reserved. All products, product specifications, and data (airflow, capacity, dimensions, or availability) are subject to change without notice, and may vary by region or country. Donaldson Torit is a registered trademark of Donaldson Company, Inc. Contains Donaldson proprietary technology.