

Donaldson®  
Torit®

**RF BAGHOUSE  
DUST COLLECTORS**

**DURA-LIFE™**  
**Twice The Life Filter Bags**



## ENERGY EFFICIENT, HIGH VOLUME DUST COLLECTOR

The rugged Donaldson® Torit® RF baghouse collector handles heavy dust loads and large volumes of air more effectively than any collector on the market.

The small footprint of the RF combines a cyclone precleaner and a baghouse into one unit. It features a powerful yet energy-efficient cleaning system, eliminating the need for compressed air to clean the bags. Combined with the revolutionary Dura-Life™ “Twice the Life” bag filters, the award-winning RF gets the job done while using much less energy than competitor collectors.

Side by side, no other baghouse provides more performance than the Donaldson Torit RF baghouse collector.

### The RF Features:

- **High-Body inlet option for abrasive dust**
- **Even-Air™ Flow Straightener reduces wear on bag filters**
- **Award winning Dura-Life™ “Twice the Life” bag filters**
- **Oval shaped bags provide better snap for better bag cleaning**
- **Clean-air bag access for easier bag service**
- **Single inlet, outlet and hopper reduces duct and hopper outlet costs**
- **60° conical hopper reduces dust build-up**
- **Requires less energy than comparable sized units**
- **RF cleaning system requires no compressed air**
- **10-year warranty**

# HIGH-VOLUME PERFORMANCE

WITH DURA-LIFE™ “TWICE THE LIFE”  
BAG FILTERS



156RFW8

## OPERATIONS &amp; FEATURES

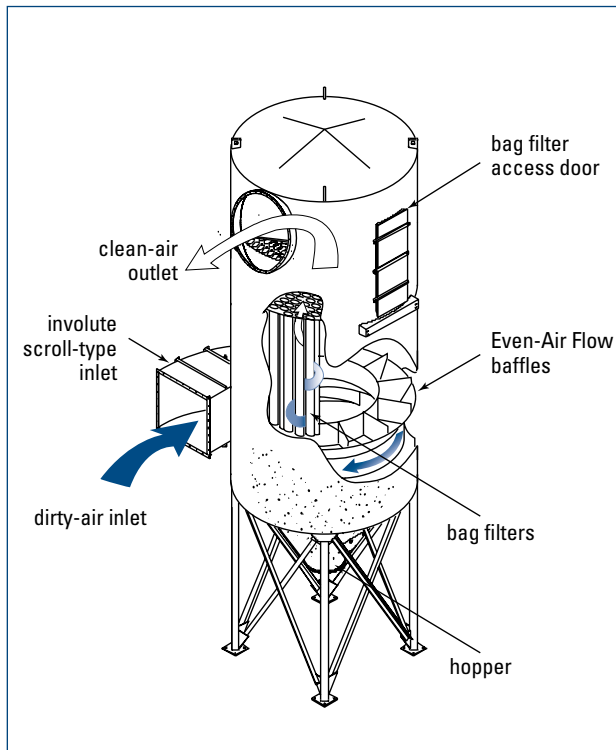

NORMAL OPERATION  
WITH INVOLUTE SCROLL INLET

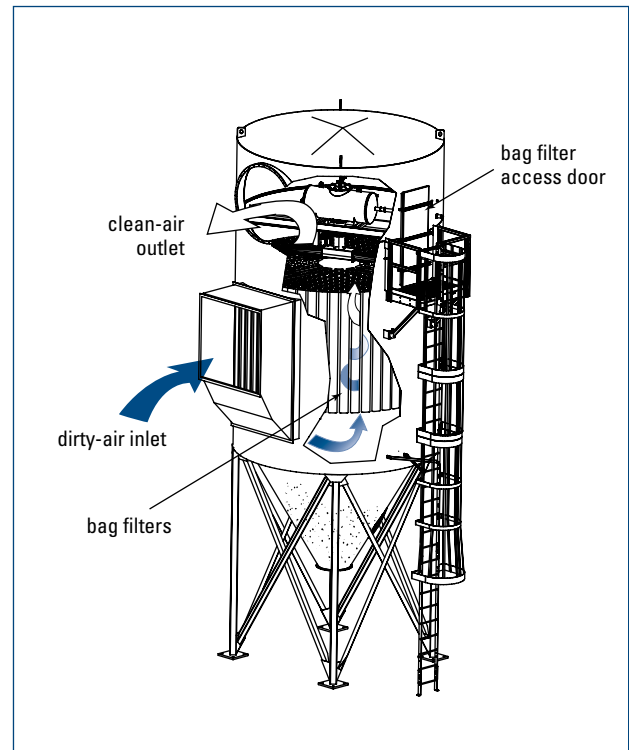

NORMAL OPERATION  
WITH HIGH BODY INLET

## BAGHOUSE OPERATIONS THAT WORK

The RF collector works so well that many competitors strive to copy its award winning design, but no one has been able to duplicate the RF's performance.

An involute scroll inlet puts dust into a cyclonic spin allowing for heavier particles to fall into the hopper, thus eliminating the need for a cyclone precleaner (for some applications with abrasive dusts, the optional high body inlet may be preferred). The remaining dust is then collected on oval shaped filter bags that provide greater snap during pulsing resulting in better bag cleaning. Rather than using expensive compressed air, the RF comes complete with a pump that provides a medium pressure/high volume pulse of air to a rotating cleaning arm timed to clean non-adjacent bag filters, thus reducing dust re-entrainment.

## OPERATIONS &amp; FEATURES

## EVEN AIRFLOW DISTRIBUTION

To prevent bag filter wear and abrasion that can occur in other collectors, the RF baghouse collector comes standard with our proprietary Even-Air™ Flow Straightener or high body inlet. Designed using sophisticated FLUENT®\* computer airflow analysis, the RF provides the most uniform airflow possible resulting in reduced bag abrasion, longer filter bag life and lower maintenance costs.

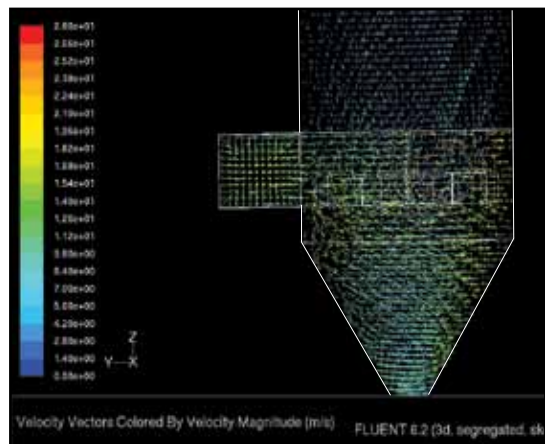

FLUENT computer airflow analysis showing airflow with involute scroll inlet and Even-Air Flow Straightener.

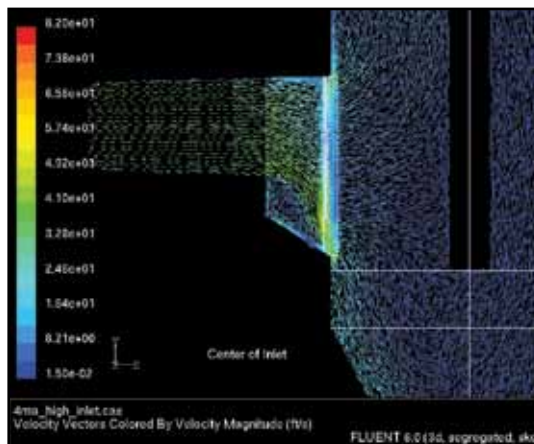

FLUENT computer airflow analysis showing airflow with high body inlet.

## BENEFITS OF THE OVAL-SHAPED BAG

Oval shaped bag filters provide better snap during cleaning as compared to round bags—allowing the dust to be more easily knocked off the bags. This results in lower pressure drop and longer bag filter life.

Oval shaped bag filters increase the amount of bag material that can fit in a given area, thus increasing collector capacity.

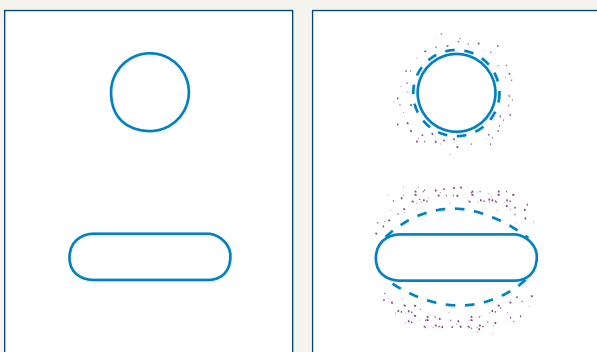

Normal Operation

Pulse Bag Operation

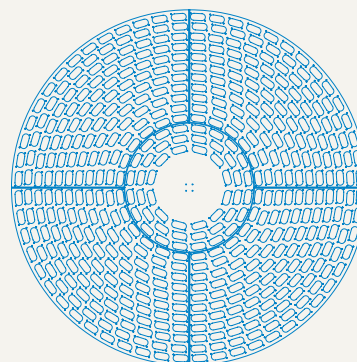

\* FLUENT is a registered trademark of Fluent, Inc.

## OPERATING ADVANTAGES

The RF cleaning system uses much less energy when compared to compressed air cleaning systems. The charts below illustrate the energy savings that can be realized for various annual operation scenarios.

### RF CLEANING SYSTEM USES LESS ENERGY THAN COMPRESSED AIR CLEANING SYSTEMS

**62%** LESS ENERGY

Weekly Operation	Annual Cleaning System vs. Compressed Air System Costs				
	Operating Hours	RF Cleaning System Operating Costs	Competitor Compressed Air Operating Costs	Savings with RF	Annual Savings
8 hrs. per day 5 days per week	2080	\$885	\$2,342	\$1,457	62%
16 hrs. per day 5 days per week	4160	\$1,771	\$4,685	\$2,914	62%
24 hrs. per day 5 days per week	6240	\$2,656	\$7,027	\$4,371	62%

Assumes the use of a 484 RF compared to a similar size collector with compressed air cleaning system.  
Assumes U.S. Energy Average Cost of 6.68 cents per kilowatt hour and a Baldor motor that is operating at full-load amps.  
Your savings may vary based on your costs per kilowatt hour and the efficiency of your motor.

### RF WITH DURA-LIFE BAG FILTERS RUNS AT A LOWER PRESSURE DROP SAVING FAN ENERGY

**50%** ENERGY SAVINGS

Weekly Operation	Annual RF Fan vs. Competitor Fan Operating Costs				
	Operating Hours	RF Fan Operating Costs	Competitor Fan Operating Costs	Savings with RF	Annual Savings
8 hrs. per day 5 days per week	2080	\$2,237	\$4,474	\$2,237	50%
16 hrs. per day 5 days per week	4160	\$4,474	\$8,984	\$4,474	50%
24 hrs. per day 5 days per week	6240	\$6,711	\$13,442	\$6,711	50%

Assumes the use of a 484 RF running 50,000 cfm at a 2" pressure drop versus a competitor collector running at a 4" pressure drop.  
Assumes the use of a variable frequency drive, a fan efficiency of 81%, 0.746 watts of energy per horsepower and a 90% electrical transmission efficiency.  
Assumes U.S. Energy Average Cost of 6.68 cents per kilowatt hour and a Baldor motor that is operating at full-load amps.  
Your savings may vary based on your costs per kilowatt hour and the efficiency of your motor.

**DURA-LIFE™ — A TECHNOLOGY BREAKTHROUGH FOR BAG USERS****STANDARD IN ALL DONALDSON TORIT RF BAGHOUSE COLLECTORS**

Traditional 16 oz. polyester bags are produced with a needling process that creates larger pores where dust can embed into the fabric, inhibiting cleaning and reducing bag life. Dura-Life bag filters are engineered with a unique hydroentanglement process that uses water to blend the fibers. This process provides a more uniform material with smaller pores, better surface loading, and better cleaning. These advantages provide twice the operating life before bags need to be replaced due to high pressure drop. Longer life from Dura-Life bag filters lowers maintenance and operating costs and raises baghouse dust collection to a whole new level.



**Dura-Life Bag-Clean Air Side**  
(300x)



**Polyester Bag-Clean Air Side**  
(300x)

These photos were taken with a scanning electron microscope of bag media used in a collector that was filtering fly ash. The bags were removed after 2,700 hours of use. Air-to-media ratio was 4.5 to 1. Pressure drop was 6 in. on polyester bags and 2 in. on Dura-Life.

**DURA-LIFE BAGS PROVIDE BIG BENEFITS**

Dura-Life technology provides better surface loading and better pulse cleaning, resulting in:

- Two to three times longer bag life
- Energy savings due to lower pressure drop
- Reduced replacement bag costs due to fewer bag changeouts
- Reduced maintenance and operating costs due to fewer bag changeouts
- 30% fewer emissions based on EPA tests



PROVEN PERFORMANCE ON HUNDREDS OF APPLICATIONS



**776RF**  
at wood furniture plant



**376RF**  
at cabinet shop



**156RF**  
on grain processing



**124RF**  
on quarrying



**356RF**  
on wood dust with high inlet  
and custom color



**484RF**  
two high temperature collectors  
on secondary aluminum processing

**DIMENSIONS & SPECIFICATIONS**

MODEL 484RFW & 608RFP (Walk-in)

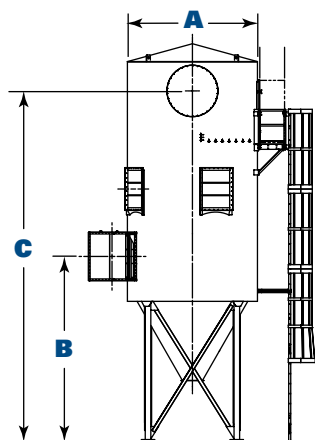

Front View - 484RFW

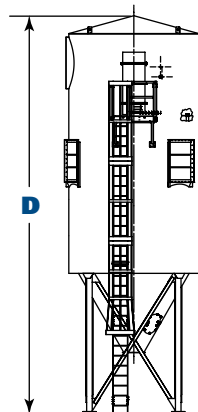

Side View - 484RFW

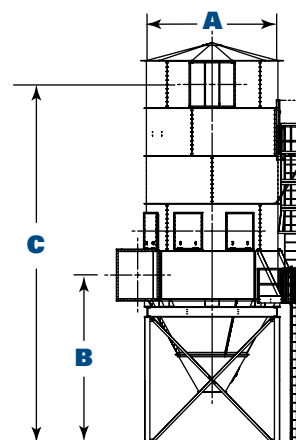

Front View - 608 RFP

MODEL 458RFWH & 570RFP (Walk-in with High Body Inlet)

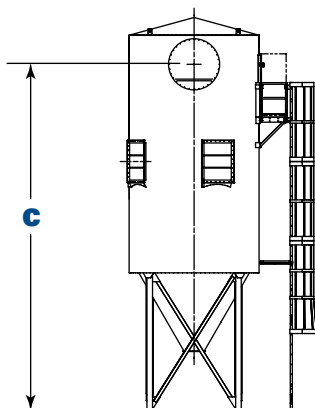

Front View - 458RFWH

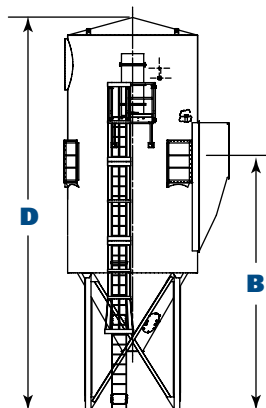

Side View - 458RFWH

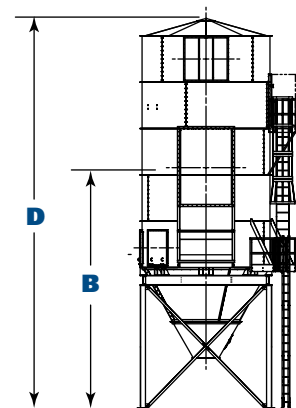

Front View - 570 RFP

MODEL 484RFT (Walk-on)

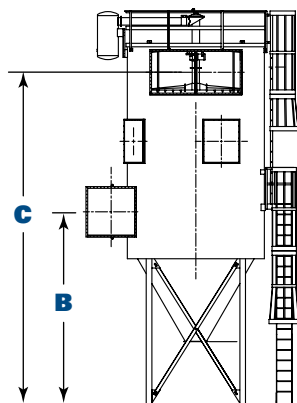

Front View - 484RFT

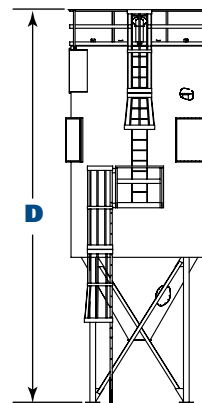

Side View - 484RFT

RF Model Nomenclature: First number denotes the number of bags and last number denotes the bag length in feet. W = walk-in plenum for sheltered bag removal; T = walk-on the top of the collector to replace bags; H = high body inlet; P = panelized construction for field assembly.



## DIMENSIONS &amp; SPECIFICATIONS

Model*	Dimensions (inches)					
			RFT		RFW	
	A	B	C	D	C	D
44RFWH8	68.0	208.8	—	—	295.8	352.5
44RFWH10	68.0	235.8	—	—	326.8	407.5
48RF8	68.0	126.8	258.3	308.8	316.8	365.5
48RF10	68.0	126.8	282.3	332.8	340.8	413.5
66RFWH8	68.0	208.8	—	—	295.8	352.5
66RFWH10	68.0	235.8	—	—	326.8	407.5
72RF8	68.0	126.8	258.3	308.8	316.8	365.5
72RF10	68.0	126.8	282.3	332.8	340.8	413.5
118RFWH8	96.0	228.0	—	—	321.0	366.0
118RFWH10	96.0	254.0	—	—	351.0	420.0
124RF8	96.0	156.0	292.5	355.6	343.0	388.0
124RF10	96.0	156.0	316.5	380.0	367.0	436.0
146RFWH8	96.0	228.0	—	—	321.0	366.0
146RFWH10	96.0	254.0	—	—	351.0	420.0
156RF8	96.0	156.0	292.5	355.6	343.0	388.0
156RF10	96.0	156.0	316.5	380.0	367.0	436.0
226RFWH8	123.0	239.4	—	—	344.4	395.1
226RFWH10	123.0	257.4	—	—	374.4	449.1
226RFWH12	123.0	275.4	—	—	404.4	503.1
232RF8	123.0	184.8	333.9	415.6	378.4	429.1
232RF10	123.0	184.8	357.9	439.4	402.4	477.1
232RF12	123.0	184.8	381.9	463.4	426.4	525.1
266RFWH8	123.0	239.4	—	—	344.4	395.1
266RFWH10	123.0	257.4	—	—	374.4	449.1
266RFWH12	123.0	275.4	—	—	404.4	503.1
276RF8	123.0	184.8	353.9	415.6	378.4	429.1
276RF10	123.0	184.8	357.9	439.4	402.4	477.1
276RF12	123.0	184.8	381.9	463.4	426.4	525.1
356RFWH8	139.6	253.8	—	—	358.8	413.1
356RFWH10	139.6	271.8	—	—	388.8	467.1
356RFWH12	139.6	289.8	—	—	418.8	521.1
376RF8	139.6	202.8	357.3	442.4	398.8	453.1
376RF10	139.6	202.8	381.3	466.4	423.1	501.1
376RF2	139.6	202.8	405.3	490.4	446.8	549.1
458RFWH8	157.6	269.4	—	—	374.6	431.4
458RFWH10	157.6	288.4	—	—	404.4	485.1
458RFWH12	157.6	305.4	—	—	434.4	539.1
484RF8	157.6	221.4	381.9	487.2	420.4	477.1
484RF10	157.6	221.4	405.9	511.2	444.4	525.1
484RF12	157.6	221.4	429.9	535.2	468.4	573.1
570RFWPH10	188.0	345.1	—	—	498.5	553.5
570RFWPH12	188.0	345.1	—	—	498.5	577.5
608RFWP10	188.0	234.2	—	—	498.5	553.3
608RFWP12	188.0	234.2	—	—	522.5	601.3
776RFWPH10	228.5	380.4	—	—	533.8	594.3
776RFWPH12	228.5	380.4	—	—	533.8	618.3
825RFWP10	228.5	269.6	—	—	533.8	594.3
825RFWP12	228.5	269.6	—	—	557.8	642.3
851RFWPH10	228.5	380.4	—	—	533.8	594.3
851RFWPH12	228.5	380.4	—	—	533.8	642.3
905RFWP10	228.5	269.6	—	—	533.8	594.3
905RFWP12	228.5	269.6	—	—	557.8	642.3

\* All units 570 and larger are of panelized construction and dimension "B" is from center of the inlet to bottom of the 36-in. hopper outlet.

## DIMENSIONS &amp; SPECIFICATIONS

Model*	Nominal Airflow Range** (cfm)	Cloth Area (ft <sup>2</sup> )	No. of Bags	Air Pump (hp)	Shipping Weight (lbs)	
					RFT	RFW
44RFWH8	2285 - 6398	457	44	2.0	—	7300
44RFWH10	2860 - 8008	572	44	2.0	—	8100
48RF8	2495 - 6986	499	48	2.0	6109	7388
48RF10	3120 - 8736	624	48	2.0	6434	8105
66RFWH8	3435 - 9618	687	66	2.0	—	7500
66RFWH10	4295 - 12,026	859	66	2.0	—	8300
72RF8	3745 - 10,486	749	72	2.0	6302	7554
72RF10	4685 - 13,118	937	72	2.0	6668	8306
118RFWH8	6140 - 17,192	1288	118	3.0	—	10,000
118RFWH10	7675 - 21,490	1535	118	3.0	—	10,900
124RF8	6450 - 18,060	1290	124	2.0	8677	10,048
124RF10	8065 - 22,582	1613	124	3.0	9214	10,910
146RFWH8	7590 - 21,252	1518	146	3.0	—	10,300
146RFWH10	9500 - 26,600	1900	146	3.0	—	11,200
156RF8	8110 - 22,708	1622	156	3.0	8933	10,298
156RF10	10,150 - 28,420	2030	156	3.0	9527	11,217
226RFWH8	11,755 - 32,914	2351	226	5.0	—	15,300
226RFWH10	14,700 - 41,160	2940	226	5.0	—	16,600
226RFWH12	17,640 - 49,392	3528	226	5.0	14,014	17,800
232RF8	12,065 - 33,782	2413	232	3.0	13,656	15,304
232RF10	15,090 - 42,252	3018	232	5.0	14,577	16,591
232RF12	18,110 - 50,708	3622	232	5.0	15,395	17,825
266RFWH8	13,830 - 38,724	2766	266	5.0	—	15,600
266RFWH10	17,305 - 48,454	3461	266	5.0	—	17,000
266RFWH12	20,760 - 58,128	4152	266	5.0	—	18,300
276RF8	14,350 - 40,180	2870	276	5.0	15,010	15,614
276RF10	17,955 - 50,274	3591	276	5.0	15,908	16,975
276RF12	21,540 - 60,312	4308	276	5.0	—	18,290
356RFWH8	18,405 - 51,814	3701	356	7.5	—	19,600
356RFWH10	23,030 - 64,848	4632	356	7.5	—	21,200
356RFWH12	27,630 - 77,798	5557	356	7.5	—	22,900
376RF8	19,550 - 54,740	3910	376	7.5	18,341	19,617
376RF10	24,460 - 68,488	4892	376	7.5	19,463	21,248
376RF12	29,345 - 82,166	5869	376	7.5	20,610	22,868
458RFWH8	24,495 - 66,696	4764	458	7.5	—	25,400
458RFWH10	30,640 - 83,426	5959	458	7.5	—	27,800
458RFWH12	36,760 - 100,086	7149	458	7.5	—	30,100
484RF8	25,170 - 70,476	5034	484	7.5	23,273	25,458
484RF10	31,485 - 88,158	6297	484	7.5	24,830	27,796
484RF12	37,775 - 105,770	7555	484	7.5	26,425	30,115
570RFWPH10	37,000 - 103,740	7410	570	20.0	—	40,049
570RFWPH12	44,460 - 124,488	8892	570	20.0	—	42,029
608RFWP10	39,520 - 110,656	7904	608	20.0	—	41,505
608RFWP12	47,420 - 132,790	9485	608	20.0	—	44,278
776RFWPH10	50,440 - 141,232	10,088	776	20.0	—	50,792
776RFWPH12	60,520 - 169,484	12,106	776	20.0	—	53,220
825RFWP10	53,620 - 150,150	10,725	825	20.0	—	53,446
825RFWP12	64,350 - 180,180	12,870	825	20.0	—	56,969
851RFWPH10	55,310 - 154,882	11,063	851	20.0	—	51,544
851RFWPH12	66,370 - 185,864	13,276	851	20.0	—	54,095
905RFWP10	58,820 - 164,710	11,765	905	20.0	—	54,255
905RFWP12	70,590 - 197,652	14,118	905	20.0	—	57,909

\* All units 570 and larger are of panelized construction.

\*\* Based on clean filters.

## STANDARD FEATURES &amp; AVAILABLE OPTIONS

Collector Design	Std	Opt
All-Welded, Knock-Down or Panelized Construction	X	
Heavy-Duty 1/4-in Tubesheet Construction	X	
Air Pump (TEFC Motor Drive) for Cleaning System	X	
1/3 HP TEFC Motor* for Manifold Drive	X	
Involute Scroll Inlet	X	
Round Outlet for RFW	X	
Rectangular Outlet for RFT and RFP	X	
Round Outlet for RFT		X
Rectangular Outlet for RFW		X
High Body Inlet		X
Ladders, Cages & Platform Assemblies (OSHA Compliant)		X
Stainless Steel Construction		X
Internal Service Light		X
<b>Bags &amp; Cages</b>		
Dura-Life Twice the Life Polyester Felt Oval-Shaped Bag Filters	X	
Galvanized Bag Filter Cages	X	
Positive Seal Boltsafe™ Hardware	X	
Grounded Bag and Cage System	X	
Snap-In Bags (8' & 10' Only)		X
Variety of Bag Filter Media Options		X
<b>Hopper Design</b>		
60° Conical Hoppers	X	
Hopper Manhole	X	
Outlet Transitions		X
Hopper Service Port		X
Hopper Level Indicators		X
3" Hopper Water Overflow Check Valve		X

Support Structure	Std	Opt
Steel Support Legs		X
<b>Electrical Controls, Gauges and Enclosures</b>		
Magnehelic®** Gauge	X	
Pulse Solenoid Valve in NEMA 9 Enclosure	X	
Solid-State Timer in Type (NEMA/UL) 4 Enclosure	X	
Photohelic®** Gauge		X
RF Electrical Control Panel		X
<b>Safety Features</b>		
Top Handrail for RFT	X	
Sprinkler Taps		X
Explosion Vents		X
<b>Paint System</b>		
Prime Coated Interior	X	
Blue Exterior Finish Coating Meets 250-Hour Salt Spray Corrosion Protection Test	X	
Hostile Environment Paint		X
Custom Colors		X
Ceramic Insulation Finish		X
<b>Warranty</b>		
10-Year Warranty	X	

\* All 60 Hz motors 1 HP and above are EISA compliant and considered NEMA Premium® per Table 12-12. NEMA Premium is a registered trademark of National Electrical Manufacturers Association.

\*\* Magnehelic and Photohelic are registered trademarks of Dwyer Instruments, Inc.



## GLOBAL SUPPORT



- Facilities in 37 countries
- 40 manufacturing plants and 14 distribution centers
- Sales offices worldwide

## LEADING TECHNOLOGY



- Over 1,000 engineers and scientists worldwide
- Broad range of innovative collectors and filters
- 100s of filter media formulations

## EXPERIENCE & SERVICE



- Technical expertise and support
- Ready-to-ship filters and parts within 24 hours
- 1,000,000+ dust, fume, and mist collectors installed



**Call Donaldson Torit  
to get Cleaner Air today  
800-365-1331  
donaldsontorit.com**